

ASSOCIATION OF PAEDIATRIC CHARTERED PHYSIOTHERAPISTSChairman

Miss R. Dawson, M.C.S.P.
19 Main Street,
East Bridgford.
Nottingham. NG13 8PA

Vice Chairman

Vacant

Secretary

Miss C. Mason, M.C.S.P.
1 Sherringham Avenue,
Tottenham,
London. N17 9RS

Treasurer

Mrs. S. Hill, M.C.S.P.
3 Bromwich Road,
Woodseats,
Sheffield. S8 0GF

P.R.O.

Miss M.E. Carrington,
202 Boroughbridge Road
York. YO2 6BD

Newsletter Editor.

NOVEMBER NEWSLETTER NO. 17Adaptive Kneeler for Handicapped Children

Terry Coletti, Med. Special Education Teacher, Arthur Trudeau Centre
Joanne Weaver, B.A., " " " " " "
Steven Jacquard, B.S. Special Education Teaching Assistant at the
same institution.

In our teaching of physically and mentally handicapped children we found many children who required adaptive equipment in order to maintain good positions. We had equipment that allowed a child to maintain sitting, standing, or sidelying positions. Our physical therapist, however, often recommended the intermediate position of two-point kneeling as advantageous for some children. Although we could have our children maintain such a position during the direct physical handling, we had no means by which a child could maintain this position independently. Our solution was the "Trudeau Kneeler" (patent pending).

Use of the Kneeler should follow evaluation and recommendation by a physical therapist or occupational therapist. Generally, the Kneeler should be used for brief periods with children who demonstrate fair or better trunk control and should be used with an activity table of appropriate height.

Construction

The Kneeler, basically rectangular, is constructed from $\frac{1}{2}$ " plywood. Figure 1 shows specific dimensions. High sides (roughly as high as the axilla) surround the child on three sides. The rest of the box extends backward with lower sides to allow room for the child's legs and to allow visual inspection of the child's position. To maintain hip extension a wide slat is slipped into one of several positions behind the child (Fig. 2). Exact placement of the slat depends on the size of the child. The entire Kneeler is situated on a flat plywood base, which prevents tipping. The open slat construction on the front and back of the box provides stability and ease of carrying. Edges can be rounded or appropriately padded for comfort and safety. A thick foam cushion extends only to the child's ankles to allow for comfortable kneeling and to encourage ankle dorsiflexion.

Acknowledgement. We wish to thank Cynthia Thomson, R.P.T., and Barbara Rowe, R.P.T., for their assistance in developing the Kneeler.

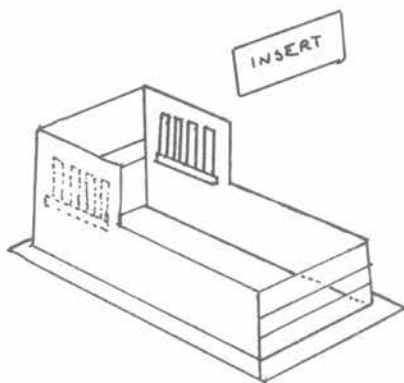

Fig. 2.

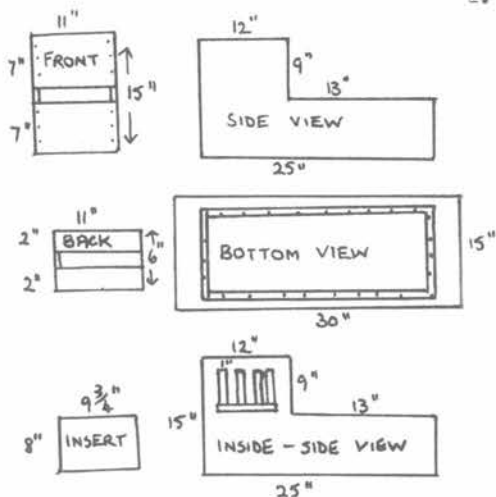

Fig. 1

Arthur Trudeau Centre, 3445 Post Road, Warwick, RI 02886, U.S.A.
 Reprinted from Physical Therapy (Vol. 59, No. 7, July 1979, 886-887)
 with the permission of the American Physical Therapy Association.

STANDING WEDGE FOR INCREASING ANKLE DORSIFLEXION.

Andrew A. Guccione, M.S. Staff Physical Therapist, Massachusetts Rehabilitation
 Hospital, 125 Nashau Street, Boston, M.A. 02114

Jean Oulund Petzet, B.S. Director, Physical Therapy Dept. " " "

Limited ankle dorsiflexion is common in patients who have been non-ambulatory for a period of time. Standing a patient with a shortened Achilles tendon presents a therapeutic challenge. Patients who are unable to achieve ankle dorsiflexion to at least neutral (0 degrees) will most often bear weight on the ball of the foot. In more extreme cases, patients may compensate at other lower extremity joints, exhibiting genu recurvatum or decreased hip extension when asked to keep the foot flat during stance.

Intervention directed towards increasing ankle dorsiflexion requires a weight bearing surface that will stretch the Achilles tendon at the end of available range. Normal weight distribution over the entire foot, without compensation at the knee or the hip, is also desired. We devised an adjustable wooden wedge to meet these requirements. (Fig 1.)

Materials: One 44" x 7" x $\frac{3}{4}$ " wood plank
 Two 4 $\frac{7}{8}$ " six-screw hinges
 One 42" length of $\frac{3}{8}$ " wood stripping

Construction:

Divide the plank into a 20 $\frac{1}{2}$ " long standing surface and a 16 $\frac{1}{2}$ " long base and a 7" long swinging support. Cut the ends of the swinging support at 45° parallel angles to permit easier movement. Cut six 7" long pieces of wood stripping. Join the standing surface end to end with the base by one of the hinges. Join the flat side of the swinging support to the underside of the standing surface at 10" from the surface-base joint. Nail the wood strips to the base so that their inner edges are at 8", 10", 12 $\frac{1}{8}$ ", 13 $\frac{1}{2}$ ", 14 $\frac{2}{3}$ ", and 15 $\frac{1}{16}$ ", measuring from the standing surface-base joint. This arrangement allows for adjustment of the wedge between 45° and 20° at 5° intervals. Reinforce each wood strip with two screws. Stain and varnish.

Treatment

The wedge is used most effectively as part of a tilt table programme. After measuring ankle dorsiflexion, the wedge is fixed at the angle closest to, but less than, the patient's available range. For example, if the patient has a 28° plantar flexion contracture (-28° neutral) the wedge should be fixed at 25° (with the patient's toes pointing towards the hinge, Ed.) As the patient gains dorsiflexion range, the wedge is lowered until it is completely folded. The folded wedge permits about 10° of plantar flexion (-10° neutral) at which point the patient is ready for a shoe with a built up heel. To decrease sliding at the steeper angles, the patient can wear foam hospital slippers. Prolonged Achilles tendon stretching through weight bearing is assured at the end of available range by the adjustable feature of the wedge. Distribution of weight across the entire foot permits stretching of any shortened intrinsic muscles of the foot, which can be difficult to achieve manually. We have found other uses of the wedge. First the folded wedge can be used reversely (i.e. patients' heels pointing towards the hinge, Ed.) to increase dorsiflexion. Further by stretching the Achilles tendon beyond the neutral position. It can also be used as a "quads boards" to perform quadriceps exercises in the supine position.

Reprinted from Physical Therapy (Vol. 59 No. 6 June 1979, 766 - 767) with the permission of the American Physical Therapy Association.

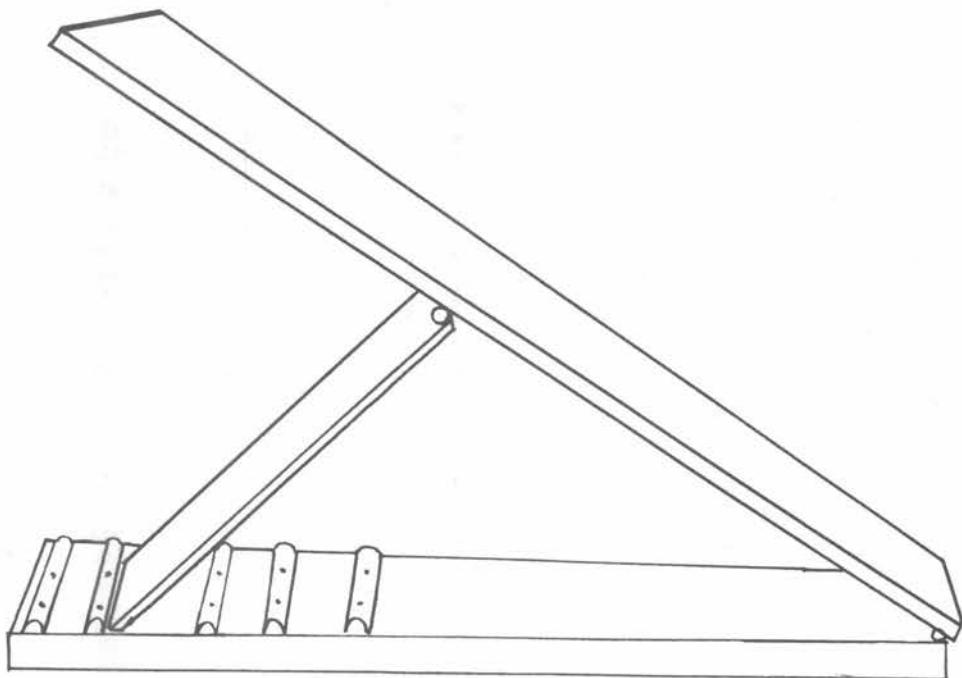

Spotlight on Counselling

Some members may remember the suggestion put forward at the London A P C P Conference in April that counselling is probably best undertaken by a person who is already wellknown to the child or young person, rather than a stranger. Are all of us in possession of the necessary skills? Courses are offered at various centres and some of the London ones are listed below:-

1. North East London Polytechnic,
Special Course Office, Livingstone House, Livingstone Road,
Stratford, London E.15. Tel. 01 - 590 - 7722

The course consists of an 11 week structured practicum in which students work in groups of 6 with a tutor

2. South West College Polytechnic.
Dept. of Management Services and Industrial Relations,
Abbotswood Road, London, S.W. 16. Tel. 01 - 487 - 5911. Ext. 59

The course consists of 3 - 1 year modules which leads to a Diploma in Counselling Skills.

3. Royal College of Nursing
Institute of Advanced Nursing Education,
Henrietta Place, London, W1 M OAB. Tel. 01 - 580 - 2646

Part time counselling course designed for those who are counselling as one of the functions within their professional role. A six month course including a residential week-end.

4. The Tavistock Clinic,
Belsize Lane, London, N.W. 3

Course title "A Psycho-analytical Approach to Families".
A one year course giving an opportunity for qualified professionals to develop their psychodynamic skills in relation to family therapy.

5. Institute of Family Therapy
5 Tavistock Place, London, W.C. 1 Tel. 01 - 388 - 3872

Course title "Introductory Family and Marital Course".
Multi-disciplinary course of lectures and seminars in family and marital work with the emphasis on developing skills in working with the family.

This course is linked to further training courses offered by the Institute.

All courses offered, with the exception of the R.C.N. one, are open to all "caring professions", provided adequate reasons for wishing to take the courses are given. The greater number of those applying are likely to be psychologists. (I am told by a London A P C P member, that the R.C.N course included one O.T. and one physio.)

If anyone has any further information on courses, I would be pleased to hear from them. EDITOR.

* * * * *

A message from Doreen Wheatley, First South West Regional Representative who has now retired.

"What a lovely surprise you gave me at the Poole Meeting. I shall so enjoy using my Parker pen and pencil and choosing my records. Thank you all very much"

WHEN ? 11th - 12th April 1981
 WHERE ? Hatfield Polytechnic, Hatfield, Hertfordshire
 THEME ? "The Pre-School Child with Special Needs".

PROGRAMME11th April 1981

- 9.30 a.m. Registration and Coffee
 9.45 a.m. Welcome - Rose Dawson, M.C.S.P., Chairman of A.P.C.P.
 10.15 am. Chairman - Miss Hamilton, M.C.S.P.
 Cambridge District Physiotherapist.
The Perinatal Period - The Vital Hours
 Speaker: Professor J. Davis, MB, BS, FRCP
 Professor of Paediatrics, Cambridge
 11.15 a.m. The Pattern of Handicap Today
 Speaker: Dr. N.R.C. Robertson, MA, MB, FRCP
 Consultant Paediatrician, Cambridge.
 12.15 p.m. Down's Syndrome
 Speaker: Rosemary York-Moore, MCSP, Dip.T.P.
 Senior Physiotherapist, LeaCastle Hospital, Woolverley.
 1.00 -
 2.15 pm. LUNCH
 2.30 p.m. Chairman. Rose Dawson, M.C.S.P. Chairman of A.P.C.P.
The Different Paths to Walking
 Speaker: David Scrutton, M.Sc. MCSP
 Superintendent Physiotherapist, Newcomen Centre.
 3.30 p.m. Development of Communication (To include Feeding)
 Speaker: Carol Miller, M.Sc, LCST.
 Director of Studies, Cardiff School of Speech Therapy.
 4.30 p.m. TEA
 5.00 - Preparation for School Placement
 6.00 p.m. Speaker: Linda Miller M.A.
 Peripatetic Teacher.
 7.30 p.m. SHERRY RECEPTION
 8.00 p.m. ANNUAL CONFERENCE DINNER.

12th April 1981

- 9.30 a.m. Discussion for A.P.C.P. Members only.
 10.00 a.m. Chairman - Cynthia Mason, M.C.S.P., G.R.S.M., A.R.C.M.
Parent Counselling
 Speaker: Dr. G.E. Roberts, MB, B.Ch. MRCP Psych., DPM
 Consultant Psychiatrist, Child Development Centre,
 Cambridge.
 11.00 a.m. COFFEE
 11.30 a.m. The Physiotherapist's Role in Helping the Multiply
 Handicapped Child
 Speaker: Sophie Levitt, B.Sc., Rand PT.,
 Developmental Therapist, Wolfson Centre.

Objectives: The theme of the course to consider some of the special problems of the handicapped pre-school child.

Level of the Course: The course is open to all disciplines working with children.

Applications to: - Mrs. S. Williams, by 20th March 1981
21 William Way
Letchworth, Herts

All A.P.C.P. members will receive an application form in January.

FEES: £41.00 for A.P.C.P. members (£45.00 non members) inclusive of accommodation, lectures and meals. Conference dinner extra.

Other information. Single lecture tickets available.
Bed and breakfast Friday 10th April at £7.00 if required.

* * * * *

NAIDEX - LONDON 1981

The Cunard International Hotel will be the venue for another aids exhibition on 28th - 30th May 1981 to mark the International Year of the Disabled Person and is to run concurrently with the Annual Conference of the College of Occupational Therapist. Further details from Naidex Conventions Ltd., Temple House, 36, High Street, Sevenoaks, Kent. TN 13 1JG. Tel. 0732 - 59533/4

DISABLED LIVING FOUNDATION

A comprehensive book list, mainly compiled by Cynthia Mason, A.P.C.P. Secretary, is now available from the D.L.F. entitled:- "Music Books for Nursery Children and those concerned with them". There are sections on song books, instrument making books, books with ideas about music making and a miscellaneous section.

ACT NOW

A campaign to focus public attention on the proposed alteration to the 1970 Chronically Sick and Disabled Act which will allow for reduction of personal services for disabled people. If you wish to defend the Act and obtain more information, contact Mr. Alan Whitehead, Chairman, Act Now, 30, Craven Street, London, W.C.2, Tel. 01 - 930 - 4200.

SPORTS & PASTIMES

1. Swimming for the Disabled.

The National Coordinating Committee on Swimming for the Disabled is a charitable organisation which aims to provide swimming for people with any physical or mental disability. Membership is open to any national organisation whose constitution indicates its interest in work for the disabled in swimming. The Committee produces a booklet outlining the methods of competition for disabled swimmers, and others on Swimming and Epilepsy, Forming a Club, Lifting and Handling Disabled People, Medical considerations and facilities, and also a bibliography (including films). Send a S.A.E. 6" x 9" to the Hon. Secretary c/o The Sports Council, 70 Brompton Road, London, SW3 1EX.

2. Yoga for the Mentally Handicapped

The Yoga for Health Foundation, Ickwell Bury, Biggleswade, Beds. SG18 9EF has a centre which caters for the handicapped/sick, offering special courses of a few days or a week. Tel. Northhill 076 - 727 - 271

3. Downhill Ski-ing

The Arroya Ski for disabled persons has been designed in the U.S.A. by Peter Axelson, rehabilitation engineering designer. The ski is a sled-like device constructed of reinforced fibreglass. The surface is gelocated like that of a boat and stainless steel edges on the bottom surface allow for turning and stopping. A special foam cushion provides a skier-sled interface akin to that of a foot in a ski boot and the ski has been equipped with safety devices such as knee and waist straps. The Arroya has been tested in various ski areas with a view to the integration of the sled-like device into ski-ing programmes which are already established for the disabled. Further information from:- Coordination of Ski Programmes for the Disabled, RER & D Mail Stop 153, Veterans' Administration Hospital, 3801 Miranda Avenue, Palo Alto, California 94304, USA.

4. News from Western Australia.

The paediatric group, of the Australian Physiotherapy Association, in Western Australia have sent us their September Newsletter containing an account of their June meeting on "Prevention and Treatment of Recreational Trauma in Childhood", held jointly with the Sports Medicine Group.

MOUNTBATTEN MEMORIAL TRUST

The Trust, which follows Lord Mountbatten's principal interests, includes in its objectives the sponsorship of technological research aimed at assisting handicapped and distressed people at home and abroad. The scope of this support will depend very much on the amount of money raised but if you are involved in any project which could possibly be seen as technological research, perhaps the Trust could help you. Further information from:- Mr. J. Barratt CVO, 2 Kinnerton Street, London, SW1. Tel. 01 - 235 - 0081.

PARENTS & CHILDREN

1. The National Children's Bureau has launched a project on Preparation for Parenthood. A national clearing house is to be set up to build up a bank of information on preparation for parenthood schemes already established for school children, young people, expectant mothers and families with young children. It will monitor new initiatives with "hard-to-reach" families, keep in touch with research projects and circulate information through publications, workshops and conferences, nationwide. The clearing house will be run by Gillian Pugh. Further information -

Helen Holden, Press and Information Officer,
National Children's Bureau, 8 Wakley Street, London EC1 V 7 QE
Tel. 01 - 278 - 9441

Preparation for Parenthood: Some current initiatives and thinking.
Ed. Gillian Pugh, Published by bureau January 1980.

2. Hawaii Early Learning Profile - HELP

A new and very interesting comprehensive growth and development guide for developmentally delayed children from 0 - 3 + years, divided into six areas of development and formatted in half month increments. The companion HELP activity guide gives 2,000 practical activities, cross referenced to the development charts. Help Charts \$ 3.49. Activity Guide \$ 14.95 - Contact - Vort Corporation, Box 1175 7 Q, Palo Alto, California 94306 USA.

3. "Get Around" Competition

Launched by BP oil and CORAD (the Government sponsored Committee on Restrictions Against Disabled People) the competition offers children of all ages the chance to identify and suggest answers to the problems faced by disabled people. There are three categories covering moveability, environment and publicity material. Children must submit their projects by May 1981

in the form of either a written study on aids, environment or attitudes or a feasibility study for a practical project. An exhibition in July 1981 will feature the best entries for which cash prizes are available. Information about the scheme is available from Beverley James, Room 0415 BP Oil Ltd., BP House, Victoria Street, London SW1E 5NJ

EQUIPMENT

1. Queenswood Scientific.

A very interesting range of Electronic aids/toys, which are mostly for children, including reward toys, gaze communicator, wobble board with visual feedback system (by departure of a spot of light from its central position) and an orientation monitor which emits a noise when the angle of tilt permitted (e.g. of head) is exceeded.

Catalogue available from: 1, The Paddock, Stubbington, Fareham Hants PO14 3NS
Tel. No. Stubb (032 - 95) 61993

2. TLC Bath Chair

Another product from Orthokinetics UK Ltd., Care chair Division, South Hampshire Industrial Park, Totton, Southampton, SO4322, Tel.0703 - 863629 This clever chair can be used in the bath, at school or at home as a mobile floor seat. It consists of an angled tubular steel frame on castors, covered by a nylon open mesh fabric which allows water through it and is also cool on dry land. The chair is long enough to support the whole body including the head, for those with little voluntary control of movement. When used as a bath chair, it pivots over the bath edge so the parent is only lifting half the weight of the child. The chair itself weighs very little.

3. Rifton Wheelmobile

Useful for the Spina Bifida Child and very similar to the Chailey Trolley, this vehicle has the advantage of forward tipping for self mounting by the child. It has small 8" wheels and a rear castor for added manoeuvrability. From the parents' point of view the high back and handle allow the child to be pushed when necessary. It folds for storage. From: Rifton Equipment for the Handicapped, Robertsbridge, East Sussex, TN32 5DR. Tel.0580-880 626

BOOKS

1. The Good Toy Guide

Basically an update on the ABC of Toys, the yearly Toy Library Association guide. It is on sale to the general public and not just available to TLA members. Good cross-references for various skills, indexed for shape, colour, size etc. Special section for toys for the handicapped which would be useful as a basic guide for parents, nursery staff etc. No age range guide - which I think is TLA policy. Many parents would like this included. Not enough line drawings as some of the toys are difficult to picture from just a description. Published by: - Inter Action Inprint in association with TLA. Price £2.95 from bookshops.

2. Helping your Handicapped Child. A step by step guide to every day problems. Janet Carr. Penguin 1980 £1.95.

3. Handicapped Children in Residential Care. Ann Shearer. Bedford Square Press 1980. £4.95. Subtitled "A study of Policy Failure" the book recommends an end to discrimination against handicapped children and the provision of the same standards of care for all children who cannot live at home.

4. Oxford Pre-school research project.

(a) Under five in Britain. I am 1. Jerome Bruner. Grant McIntyre 1980
£3.95

(b) Child watching at play group and nursery school. I am 2. K. Sylva,
C. Roy, M. Painter. Grant McIntyre 1980. £4.25

- (c) Children and Minders. I am 3. B. Bryant, M. Harris, D. Newton Grant McIntyre 1980. £3.95
- (d) Children and Day Nurseries. I am 4. C. Garland, S. White Grant McIntyre 1980. £2.95.
5. Orthotics etc. Second Edition. Edited by J.B. Redford, M.D., University of Kansas Medical Centre with 19 contributors. June 1980 Pub: - Williams and Wilkins. Rehabilitation Medicine Library Series Approx. £36. Comprehensive survey including externally powered devices, pressure garments for burns, orthotic management of children, respiratory aids, communication aids as well as calipers etc.
 6. Neonatal Neurology. Gerald M. Fenichel. M.C., 1980. £14.00 Includes chapters on convulsions, hypotonia, arthrogryposis, rigidity, asphyxia, infectious diseases and trauma. The emphasis is on conditions which either produce symptoms or which must be treated within the first 30 days of life.
 7. Red Thread Riddles. V.A. Jensen and P. Edman. March 1980. Collins Publishers £3.95. Picture book with raised shapes and text in print and braille for blind and partially sighted children.
 8. Making Music with the Young Handicapped Child. Elaine Streeter, Music Therapy Publications, 32 Durand Gardens, London. S.W.9. £1.50 (inc. p. & p.) Recommended by Cynthia Mason.
 9. Your Child's Speech and Language. M. Courtman-Davis, F.C.S.T. The Bodley Head. £7.50 Written by a speech therapist with parents in mind, the book emphasises the parental role in training the child. Full of practical ideas.
 10. Helping Sick Children Play. Barbara F. Weller. Bailliere Tindall. 1980 £2.95

Members are reminded that the above list is for information and does not represent any recommendation by APCP. Editor.

ARTICLES.

1. Fraser BA et al. Gross motor management of severely multiply impaired students. Vol. 1 Evaluation guide. Vol. 2 Curriculum model Baltimore. Univ. Park Press. 1979.
2. Mental Handicap Reading lists. 70 from IRMMH, from BIMH Info. & Resource Centre. 20p per copy.
3. Smithells. R.W. et. al. Possible prevention of neural tube defects by peri-conceptional vitamin supplementation. Lancet. 1. 8164. 16 Feb. '80. 339.
4. Young R & Clements J. The Functional Significance of complex hand movement stereo-types in the severely retarded. Brit. J. Ment. Subnormality 25 Part 2. 49 Dec. 1979. 79 - 87.
5. Lydic J.S. et al. Assessment of the quality of sitting and gait patterns in children with Down's Syndrome. Physical Therapy. 59. 12 Dec. 1979 1489 - 1494.
6. Ziter, F.A. and Allsop K.G. The value of orthoses for patients with Duchenne Muscular Dystrophy. Physical Therapy, 59. 11. Nov. 1979 1361 - 1365
7. Valman, H.B. The First Year of Life - some congenital abnormalities. BMJ 280 - 6206. 5th Jan. 1980. 24 - 26
8. Overcorrection - a procedure for reducing disruptive and self stimulatory behaviour. Aust. J. Ment. Retard. 5. 6. June 1979. 234 - 237

REPORTS

1. Development Team for the Mentally Handicapped.
Second report 1978 - 1979 (1980) on services and facilities provided by statutory authorities and how services have developed since the first report in December 1977. HMSO. £2.75
2. A System for Assessment and Intervention for the Pre-School Profoundly Retarded Multiply Handicapped Children. Judy Sebba. M.Ed. Available from: - Judy Sebba. M.Ed. Anson House. Pre-School Project, 9 Anson Road, Victoria Park, Manchester 14. £2. Research report on 5 special care children.
3. APMH 1978 Conference Report.
"Progress in Practice". 200 pages. 75p (inc. p & p.) Includes Portage system, Pathways employment project, special care. From Association of Professions for the Mentally Handicapped, 126 Albert Street, London NW1 ^{TNF}
"Teamwork in mental handicap", - the 1980 Conference report, free on receipt of SAE. "Assessment - Then What" - 1979 report available this month.
4. The Black Report. Report by the Work Group on Screening for Neural Tube Defects. Evidence for and against the prevention of birth of severely handicapped babies and the ethical issues involved. Free from Health Publications, Scholefield Mill, Nelson, Lancs. BB9 0HU

FILMS AND TELEVISION

"A Marvellous Beginning". 16 m.m. Colour. 10 minutes. 1980
Made by the National Coal Board in cooperation with the Spastics Society as part of the "Save - a - Baby" campaign, it emphasises the need for more enlightened ante-natal care.

Also - "Feeling Special". 16 m.m. 25 mins. Concord Film Council, 201 Felixstowe Road, Ipswich, Suffolk. Free loan. Sponsored by Spastics Society. Ante-natal care and prevention.

"Accident of Birth - Aspects of Mental Handicap". Repeat on BBC 2 at 2.15 p.m. between Nov. 4th and Dec. 9th. Brian Rix's series "Let's Go" is also being repeated.

"Child Development Centre". Charing Cross Hospital. 16 m.m. 30 mins. Sponsored by Cow & Gate. Shows work on diagnosis and stresses early discovery.

USEFUL INFORMATION

1. Haemophilia booklets. Published by and available from World Federation of Haemophilia, 1170 Peel Street, Montreal, Quebec, H3 2T4, Canada. In English and Spanish. They deal with home therapy, school, surgery, orthopaedics.
2. APMH - One of the Family. D, Hart and J. Walters. 30p. post free with reduction for 10 or more copies. The Disabilities Study Unit. July 1980
For siblings of children with handicaps to promote thinking and understanding. DSU. Wildhanger, Amberley, Arundel. West Sussex BN18 9NR
3. Home Based Intervention Programmes for Handicapped Children.
Fact Sheet No. 10 from Voluntary Council for Handicapped Children. Free
Studies summarised show provision of early intervention has a positive effect on development. VOLCUP, 8 Wakley Street, London, EC1V 7QE

4. Mr. John, the Zookeeper. Delightful explanatory booklet for diabetic children from Wellcome Medical Division, The Wellcome Foundation Ltd., Crewe, Cheshire.
5. "Know How". by G. Morby. A guide to information sources. Community Information Project, c/o Library Association, 7 Ridgemount Street, London WC1E 7AE.
6. Multicultural Books for Our Children. Compiled by Jan Knott with Harmony People. A summary of books available which feature children and families with different racial backgrounds. From Carol Carnall, Harmony, 42 Beech Drive, Borehamwood, Herts. WD6 4QU. Tel. 01-953-882

NEWS FROM THE REGIONS

Scotland. Reg. Rep. Mrs. Lesley Furnell, Glensherup House, Glenderon by Dollar, Perthshire.

March 14th. "Cystic Fibrosis" Study Day to be held in Glasgow. Please contact Reg. Rep. for details.

North East. Reg. Rep. Mrs. J. Simpson, The Black Bull Inn, Market Sq., Middleham, N. Leyburn, N. Yorks.

A day course on Still's Disease was held at York District Hospital on 27th September, and was attended by 40 people; 29 members and 11 non members. Attendance figures were less than usual, probably because a more specific topic was offered, attracting, with the exception of 2 teachers, physiotherapists and remedial gymnasts.

Jan. 20th 1981. Seacroft Child Development Unit, Leeds. Speaker to be confirmed.

Future Courses. A day course in Hull, hopefully at Frederick Holmes P.H. School, on "Usual and Unusual Neuromuscular Conditions". Speakers to include the Senior Medical Research Lecturer and the Research physio from The Hammersmith Hospital, London. Regional A.G.M. will be held at this meeting.

North West Reg. Rep. Mrs. P. Eckersley, 62 Goulden Road, Didsbury, Manchester M20 9YF

There are 123 members in the region. The Mental Handicap weekend in September at Brockhall Subnormality Hospital was fully booked and very successful.

Nov. 27th - 28th. "Patient Audit and POMR". Burnley General Hospital. Miss I. Bromley and Miss M. Harrison. Places still available but numbers limited. Apply to Reg. Rep.

Feb. 14th 1981. Audiovisual day at Royal Manchester Children's Hospital, Pendlebury. Programme of slides, tapes etc. almost finalised. Also N.W. Regional A.G.M. £3.50 members. Contact Reg. Rep. for details.

South East Reg. Rep. Miss P Charon, Physio Dept. Royal Alexandra Children's Hospital, Brighton.

Feb. 7th 1981 Day course on Mental Handicap at Queen Elizabeth II School (ESNS) Comptons Lane, Horsham, Sussex.

10.30 a.m. The Special Care Class.
Mrs. B. Munro, MCSP Queen Elizabeth II School

11.20 a.m. The Opportunity Play Group.
Mrs. S. Wilks, O.T.

11.55 a.m. The Nursery Class.
Mrs. L. Tidmarsh, Teacher, Court Meadow School, Cuckfield.

LUNCH and look round school

- 1.30 p.m. Mental handicap after school.
Various speakers, including parent.
- 3.30 p.m. Questions
- 4.00 p.m. TEA

£5.50 members. £6.50 non-members (including Lunch etc.)

Applications to Miss S. Raymond, MCSP. 58 Gates Green Road,
West Wickham, Kent. S.A.E. Please

South West Reg. Rep. Miss T. James, 23a High West Street, Dorchester, Dorset.
DP1 1UW

A. Study Day on "The Clumsy Child" was held at Dorchester on Oct 11th and attracted psychologists, teachers, O.T's, Speech Therapists, School Medical Officers and Physiotherapists.

Feb. 1981 Study Day and Regional A.G.M. "Genetics".
To be held in Exeter. Further details later.

April 1981. National Conference APCP. Provisionally booked at Weymouth College. Subject "Community Paediatrics".

London Reg. Rep. Miss M. Veach, Physiotherapy, Elizabeth Fry School
Suffolk Road, London E.13

Regretfully Marion Whyte has retired as Regional Representative and been replaced by Maxine Veach. The committee noted with appreciation Marion's inspiration and dedication to post-registration education. There was a Study Day on 27th September at Great Ormond Street - "Getting in Touch with Tactile Stimulation". Speakers were Liz Carrington, Dr. K.P. Murphy, and David Bryne.

Nov. 15th. "Recent Advances in Spina Bifida and Hydrocephalus Treatment"
Chairperson - Moyna Gilbertson, M.C.S.P.

9.30 a.m. Registration

10.00 Bony Spinal Problems and Deformities. Mr. P.Webb.FRCS.

11.00 Perceptual Problems related to Training.
Carole Sobkowiak MCSP
Leonie Holgate, MCSP

12.00 LUNCH

1.30 p.m. "Indwelling and Intermittent Catheterisation"
Dr. G. Hunt M.B., B.Chir., D.C.H.,

2.30 Problems found on Independence Courses. Jill Vernon B.Sc.,

3.30 TEA

Bookings to Mrs. J. Maughan MCSP. 16, Lee Road, Greenford, Middx.

Spring 1981. "Introduction to Counselling". South West College Polytechnic will organise a weekly session for approximately 10 weeks. Subjects under consideration for future courses - Muscular Dystrophy, Brittle Bones, Neurophysiology and Facilitation.

Midlands and Trent Reg. Rep. Miss R. Dawson, 19 Main Street, East Bridgford, Nottingham.

A lecture on Scoliosis was held in Birmingham in November.

East Anglia. Reg. Rep. Mrs. M. Norris, 10 Oakfields Road, Knebworth, Herts.

Plans are well in hand for the next APCP Conference. The Programme will appear in the CSP Journal, November issue. Those wishing to attend are urged to plan to send money with their booking and to seek reimbursement from employing authorities later. All members of APCP will receive a booking form in the New Year. (See Conference 1981)

Members 129

Wales Reg. Rep. Mrs. W. Williams, 12 Gellogaer Gardens, Cathays, Cardiff

In September the Wales region met at Pentwyn Special School to hear about

- 1) "The Health Visitor's role in Special Schools"
- 2) "Alternative Methods of Communication"

On October 22nd there was a seminar on "Cystic Fibrosis", including a film on Bronchial Lavage at University Hospital

On October 29th at the Kruff Institute, Cardiff Royal Infirmary Professor Ascher spoke on "Kidney Disease in Childhood".

COURSES DIARY

National Centre for Training and Education in Prosthetics & Orthotics

Dec. 15th - 19th Course No. NC 301. Lower Limb Orthotics (for physios and O.T's)
Normal and pathological locomotion, assessment, prescription, fit, materials and pathological gait analysis. Fee. £110.

Feb. 2nd - 6th 1981. Course No. NC 302. Lower Limb Prosthetics
(for physios and O.T's) Fee. £110.

Amputation and Tissue management, biomechanics, gait training, prosthetic components.

** Course fees are normally waived for U.K. N.H.S. staff.

Further information from Prof. J. Hughes, National Centre for Training and Education in Prosthetics and Orthotics, University of Strathclyde, Rottenrow East, Glasgow, G4 0NG, Tel. 041-5524400 Ext. 3298

Toy Library Association

Dec. 1st '80. "Play, Toys and Toy Libraries in Mental Handicap Hospitals".
£11.50 inc. food. Venue:- King's Fund Centre, London.

Copy of TLA report on subject. £3.50. Contact Sharon Kivity, Information and Training Officer, Toy Library Association, Seabrook House, Wyllyotts Manor, Darkes Lane, Potter's Bar, Herts EN6 2HL
Tel. 0707-44571

Jan. 1981 "Visual Handicap"

Cost £5.50 (inc. VAT) Members. £6.00 (inc. VAT) non-members.
Venue: TLA Headquarters, Seabrook House etc. as above.
More details on application to Sharon Kivity.

Active

Nov 20th '80. "New Developments for the Handicapped Child".

Park Dean School. Fees including refreshments and lunch £7. professionals. £5. relatives of handicapped people and non-professionals £4.

Applications to the Head Teacher, Park Dean School, St. Martin's Road, Pitton Hill, Oldham. OL8 2PY. Tel. 061-633-1409

Dec. 6th '80 Intensive day course on technical aids for mentally and physically handicapped children. Fees as above. Full details from The Headmaster, Frederick Holmes School, Inglemire Lane, Hull. HU6 85

Association of Professions for the Multiply Handicapped

Feb. 1981 Mental Handicap: Five to Twelve's Special Needs.
 April " Mental Handicap: Interdisciplinary training.
 Venue:- King's Fund Centre, London.

For further information contact the Secretary of APMH at
 126, Albert Street, London, NW1 7NF. Tel. 01-267-6111

Disabled Living Foundation - Day Courses

Feb 5th - 6th 1981. Personal toilet and the problems of incontinence.
 April 2nd/3rd 1981 Hoists.

Further details from The Course Secretary, The Aids Centre,
 Disabled Living Foundation, 346 Kensington High Street, London W14 8NS
 Each course is for one day - repeat on following day.

Voluntary Council for Handicapped Children

Dec. 9th '80. Grief and Loss. Helping the family at the birth or death of a handicapped child.
 8 Wakley Street, Islington, London, EC1V 7QE. Tel. 01-278-9441

Paediatric Interest People

Dec. 10th '80 Short term residential training for mentally handicapped children with severe behaviour problems. Contact Lorraine Clarke, The Wolfson Centre, Mecklenburgh Square, London, WC1N 2AP. 01-837-7618

Castle Priory College

Nov. 23rd - 25th '80 Course No. 16/80. The Use of Vibration in diagnosis, therapy, treatment and education of multi-disabled ESN(S) children. Tuition £26. Residence £26.

Dec. 1st - 4th '80. Domicillary Services for Mentally Handicapped People and their families. For all involved workers. Ideas from home and abroad. Tuition £33. Residence £39.

Contact Mrs. J.W. Knowles, Principal of College, Thames Street, Wallingford, Oxon, OX10 0HE. Tel. 0491-37551

P.S. Who thought up the idea of The International Year of Disabled Persons?
 Mansur Rashid Kikhia, Libyan Ambassador to the United Nations.

SUBSCRIPTIONS FOR 1981.

Dear Member,

We would like to inform you that your subscription for the year 1981 will be due on January 1st., 1981. As agreed at the 1980 AGM the subscription has increased to £3.00 per year for ALL members. This is the first increase since the inception of the Association and is unavoidable due to rising costs of postage and printing etc. (NEW members i.e. those who joined after 1st October, 1980 are fully paid up until December, 31st 1981).

We would be grateful if ALL MEMBERS would return the renewal form below appropriately completed as soon as possible. This will be a valuable means of updating our records so that we can operate more efficiently for your benefit in the coming year.

A banker's order form is overleaf. If possible, please use this method to pay your subscription. Send the completed forms to the hon treasurer. With thanks for your continued support of the association.

Yours sincerely,

Sandra Hill,
Hon. Treasurer.

TO: MRS. S. HILL, M.C.S.P. 3, BROMWICH ROAD, WOODSEATS,
HON. TREASURER, A.P.C.P., SHEFFIELD S8 09F.

MEMBERSHIP SUBSCRIPTION RENEWAL 1981.

PLEASE USE BLOCK CAPITALS THROUGHOUT

*delete as appropriate.

NAME - *MRS/MS/MISS/MR/DR.....

PROFESSION (.....CSP number if applicable).....

ADDRESS FOR CORRESPONDENCE.....

.....

.....

TELEPHONE NUMBER.....

PLACE OF WORK.....

I WISH TO RENEW MY MEMBERSHIP OF A.P.C.P:-

1. *AND WOULD LIKE TO PAY BY BANKER'S ORDER AND HAVE FILLED IN THE FORM ABOVE AND OVERLEAF.
2. *AND ENCLOSE A CHEQUE FOR £3.00 MADE PAYABLE TO A.P.C.P.
3. *AND HAVE ALREADY PAID MY SUBSCRIPTION FOR 1980/81 HAVING JOINED SINCE 1st OCTOBER, 1980.

4. I AM AN HON. MEMBER.

Date.....Signed.....

LEAVE BLANK MEMB. NUMBER.....

FOR OFFICE USE REGION.....

STANDING ORDER MANDATE

To: (Name & Address of member's bank)

.....

.....

Please pay WILLIAM'S AND GLYN'S BANK,
28, GREAT ORMOND STREET,
LONDON W.C.1. (16-00-37)For the credit of the Association of Paediatric Chartered Physiotherapists
(Account number 11235166)The sum of £3.00 THREE POUNDS commencing on the 1st day of January, 1981,
and thereafter make like payments on the 1st day of January annually until
you receive further notice from me in writing and debit my account accordingly.This instruction cancels any previous order in favour of the beneficiary
named above under this reference and also under reference Midland Bank,
Moseley Branch (40-11-16) account number 50649996.

Name.....

Address.....

Date.....Signed.....